

Part Number : V125BL

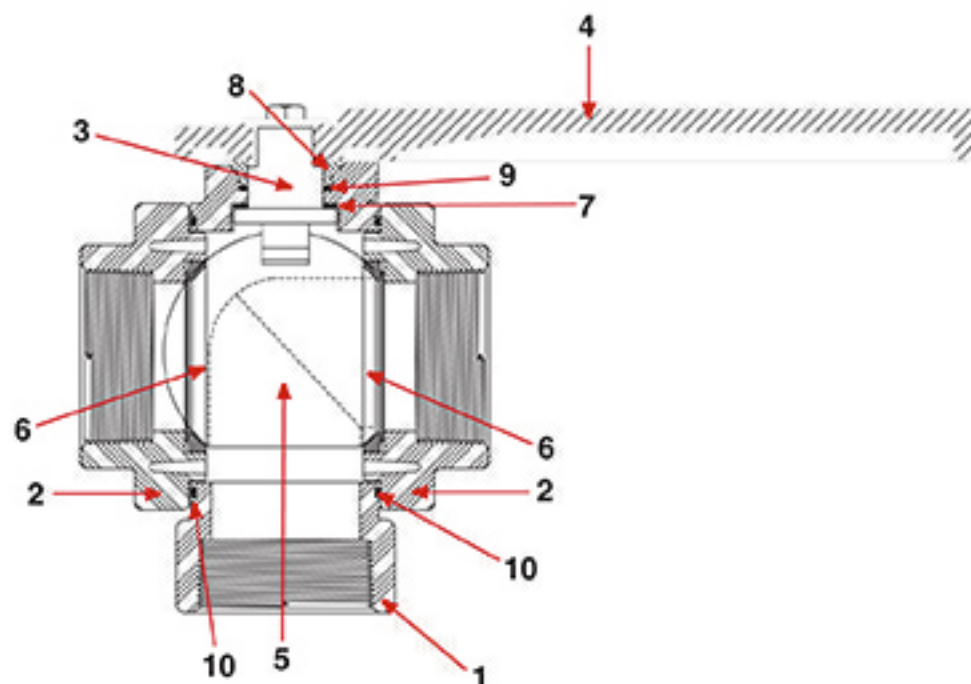

Item	Part No.	Description	Qty.
1	V20344B	1¼" Valve Body	1
1	V20354B	1½" Valve Body	1
2	V20267	1¼" End Plate	2
2	V20257	1½" End Plate	2
3	V20151M	Stem	1
4	V20353TB	Handle -T	1
5	V20355B	Ball	1
6	VE20258A	Seats	2
7	V20060	Thrust Bushing	1
8	V20159	Upper Stem Bushing	1
9	V20163	FKM (viton type) Stem O-Ring	1
10	V20264	FKM (viton type) Body O-Ring	2

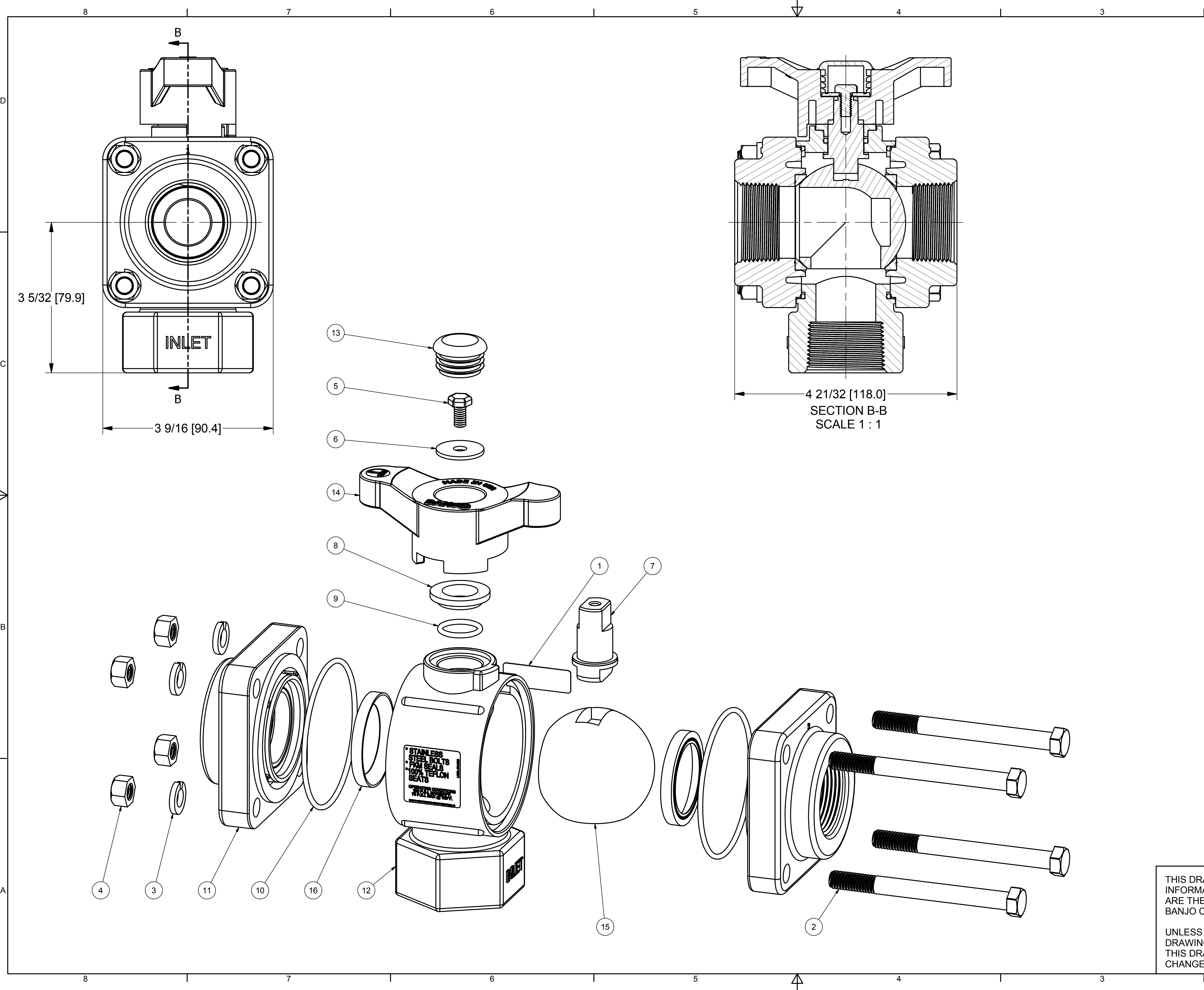

Parts List			
ITEM	QTY	PART NUMBER	DESCRIPTION
1	1	050DECAL	Banjo Logo Decal
2	4	V20017	3/8-16 X 4" HHCS
3	4	V20018	3/8" LOCKWASHER
4	4	V20019	3/8" HEX NUT
5	1	V20020	2" handle Bolt
6	1	V20021	Handle Washer
7	1	V20151M	VALVE STEM W/ BEARING
8	1	V20159	2" STEM BUSHING
9	1	V20163	#116 O'RING, FKM
10	2	V20264	#151 O'RING, FKM
11	2	V20267	1 1/4" NPT END PLATE
12	1	V20344B	1 1/4" BOTTOM LOAD VALVE BODY
13	1	V20353C	1 1/8" CAPLUG
14	1	V20353TB	2" BOTTOM LOAD T-HANDLE
15	1	V20355B	2" 3-Way BL Ball
16	2	VE20258A	2" VE Seat TFM

THIS DRAWING AND ALL INFORMATION CONTAINED THEREON ARE THE EXCLUSIVE PROPERTY OF BANJO CORPORATION.

UNLESS SPECIFICALLY NOTED, THIS DRAWING AND ITEMS SHOWN ON THIS DRAWING ARE SUBJECT TO CHANGE AT ANY TIME.

BANJO CORPORATION
 150 BANJO DRIVE, CRAWFORDSVILLE, IN 47933
 WEB SITE: WWW.BANJOCORP.COM
 E-MAIL: SALES1@BANJOCORP.COM

DESCRIPTION
1 1/4" Bottom Load 3-Way Valve

PART NUMBER
V125BL