

**Part Number : 222PBI**

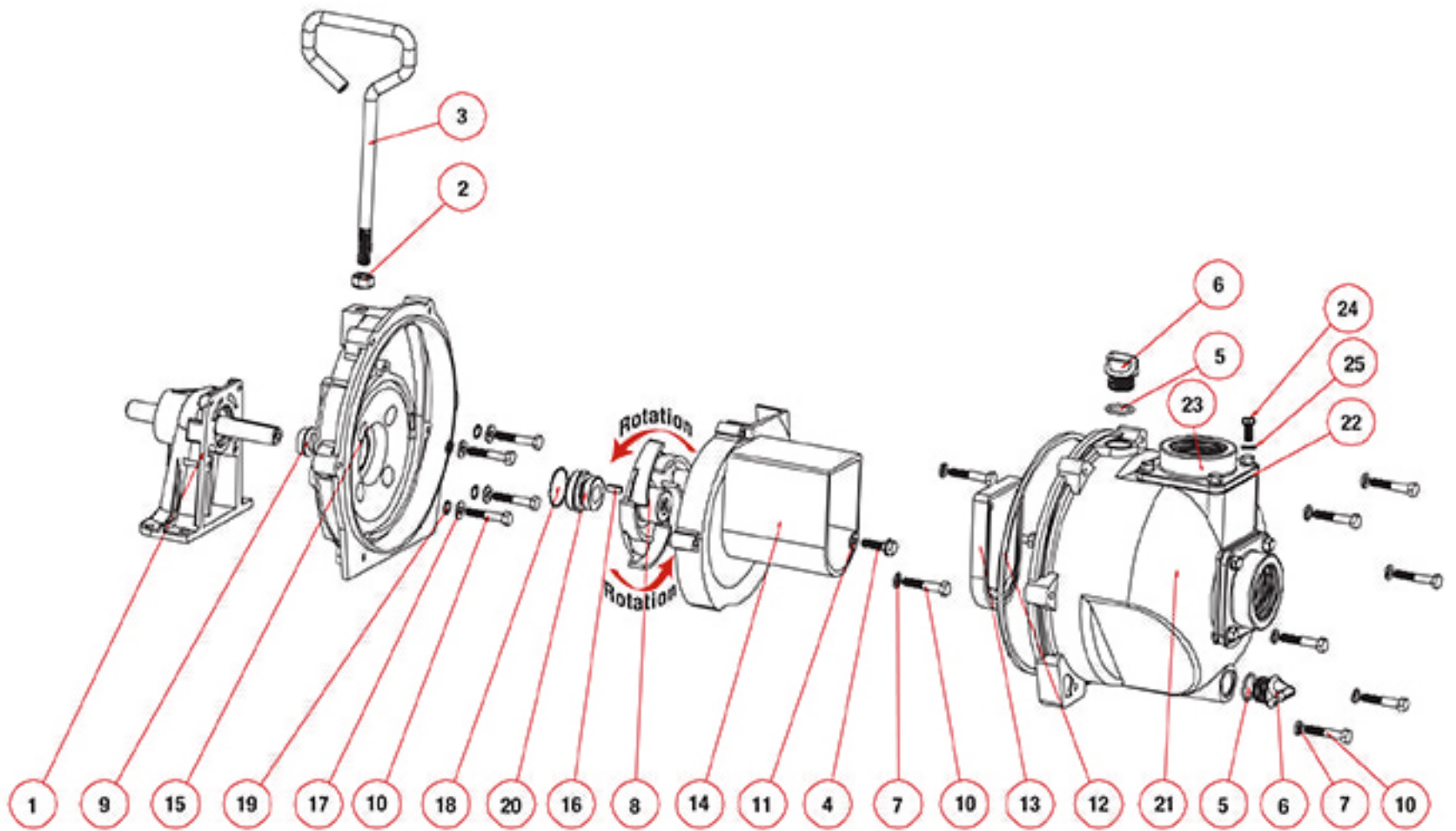

Item	Part No.	Description	Qty.
1	12882A	Bearing Pedestal Assembly	1
2	17010	½" Jam Nut	1
3	15022	Handle	1
4	12765A	5/16" - 24 x 1.12 Impeller Bolt	1
5	13778	O-Ring	2
6	13777	Prime/Drain Plug	2
7	V10118	5/16" Lock Washer	9
8	15772	5 Vane Impeller	1
9	12716	Pump Slinger	1
10	12715A	5/16" - 24 x 1.75 HHCS	13
11	12774VA	Impeller Bolt Gasket	1
12	12719A	Body O-Ring	1
13	12705	Check?Valve	1
14	15702	Volute	1
15	15703	Rear Bracket	1
16	12902A	3/16" sq x 5/8" Impeller Key	1
17	12901	5/16" Flat Washer	4
18	12710	O-Ring	1
19	12717	O-Ring	4
20	12713V	Seal Assembly	1
20	12713SD	Severe Duty Seal	1
21	15712	Body	1
22	17013	Flange Outlet Gasket	2
23	17000	Threaded Flange	1
	12099	7/16"-14 x 1.25" HHCS	1
	15751	Bracket Shim	1
	15752	Impeller Shim	1
	17033	Z-Rails	
	17034	5/16" - 18 x 1¾" Zinc Plated	4
	V10119	5/16" -18 Hex Nut	4
	V10118	5/16" Lock Washer	4
	15000	Repair Kit(Items 5, 8, 11-13, 18-20, 12099, 15751 & 15752)	1
	15000V	FKM (viton type) Repair Kit	1
	15999	Seal Kit Seal Kit (Items 5, 11-13, 18-20, 12099, 15751 & 15752)	1
	15999V	FKM?(viton type) Seal Kit	1

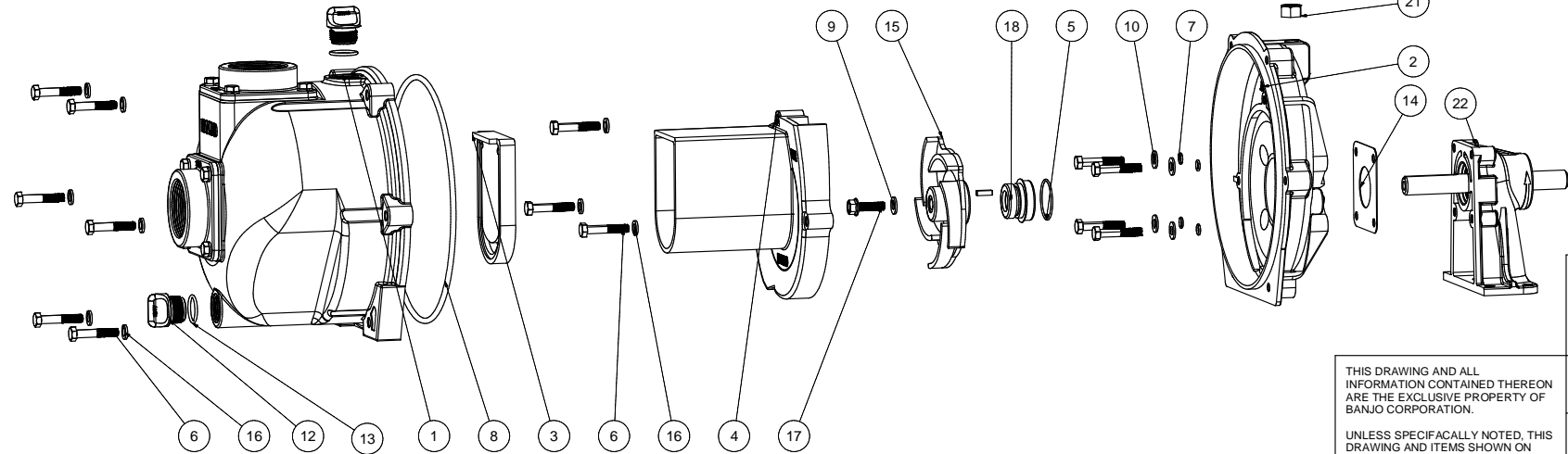
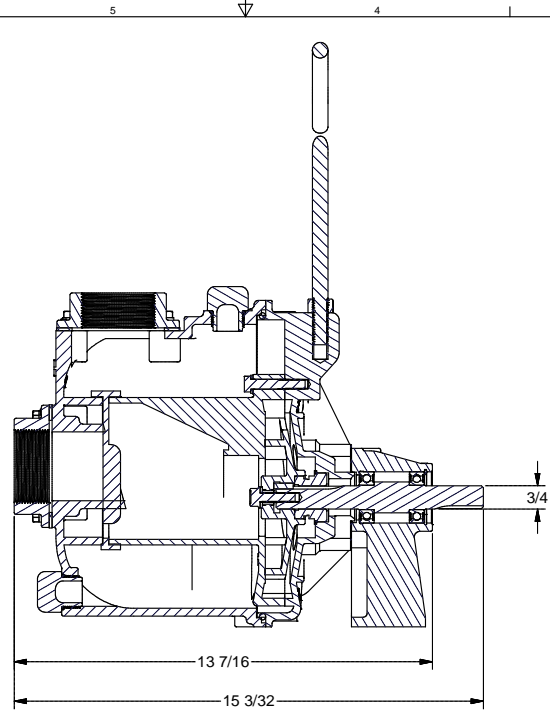
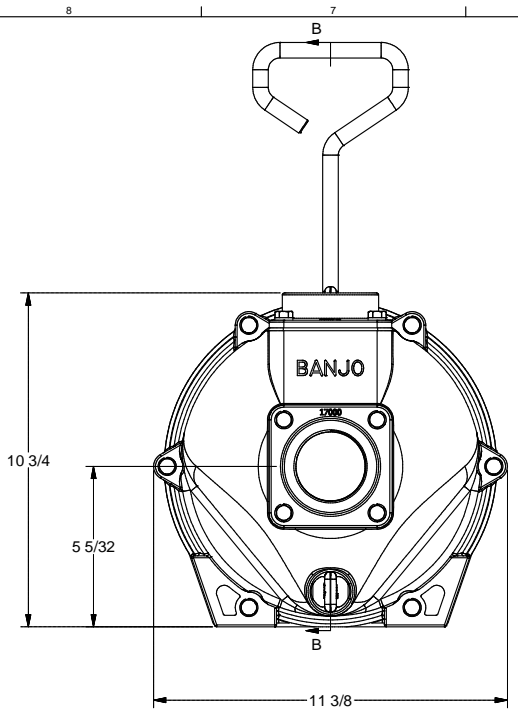

Parts List			
ITEM	QTY	PART NUMBER	DESCRIPTION
1	1	15712	2" CI PUMP BODY ASSY
2	1	15703	2" CI REAR BRACKET
3	1	12705	CHECKVALVE
4	1	15702	2" CI PUMP VOLUTE
5	1	12710	#029 O-RING
6	13	12715A	5/16-24 X 1 3/4" HHCS
7	4	12717	#11 O-RING
8	1	12719A	#375 O-RING
9	1	12774VA	IMPELLER BOLT GASKET
10	4	12901	5/16" FLAT WASHER
11	1	12902A	3/16" SQ. X 5/8" KEY
12	2	13777	3/4" DRAIN PLUG
13	2	13778	2-119 O-RING
14	1	15751	REAR BRACKET SHIM
15	1	15772	5 VANE IMPELLER
16	9	V10118	5/16" LOCKWASHER
17	1	12765A	5/16-24 X 1 1/8" HFS
18	1	12733V	MECH SEAL ASSY - FKM
19	1	12910	DECAL (N/S)
20	1	15022	2" PUMP HANDLE
21	1	17010	1/2-13 HEX NUT
22	1	12882A	BEARING PEDESTAL

THIS DRAWING AND ALL INFORMATION CONTAINED THEREON ARE THE EXCLUSIVE PROPERTY OF BANJO CORPORATION.

UNLESS SPECIFICALLY NOTED, THIS DRAWING AND ITEMS SHOWN ON THIS DRAWING ARE SUBJECT TO CHANGE AT ANY TIME.

**BANJO CORPORATION**  
 150 BANJO DRIVE, CRAWFORDSVILLE, IN 47933  
 WEB SITE: WWW.BANJOCORP.COM  
 E-MAIL: SALES1@BANJOCORP.COM

DESCRIPTION  
**2" CI PUMP W/ BEARING PED.**

PART NUMBER  
**222PBI**