



P/N 38095

P-MAX

Self-Priming Centrifugal Pump

The MP Pumps P-MAX is a high performance gasoline driven self-priming centrifugal pump. Its lightweight construction makes it ideal for portable transfer in agricultural, industrial, marine and commercial applications.

P-MAX pumps are constructed of polyester resin with Buna N mechanical seals. Pumps are equipped with a role cage, (2) 2" NPT adapters, (2) 2" hose adapters, band clamps and suction strainer. The pump is capable of a 20 foot suction lift.

The 6.5 HP engine is EPA and CARB certified.



Application:

- Tank Filling
- De-watering
- Lawn and Garden Watering
- Dirty Water
- Salt Water
- Flood Control

Construction:

- Polyester

Gasoline Engine:

- 6.5 HP/3600 RPM
- EPA Certified
- CARB Certified

Port Sizes:

- 2" NPT Adapters
- 2" Hose Adapters

Seal:

- Carbon/Ceramic/Buna N

SPECIFICATIONS:

Housing	Polyester
Adapter	Polyester
Impeller, 3-Blade	Polyester
Flapper	Buna N
Mechanical Seal	Carbon/Ceramic/Buna N
Engine, Gasoline	6.5 HP
Weight	51 LBS

* Not intended for transferring flammable liquids.

P-MAX Dimensions

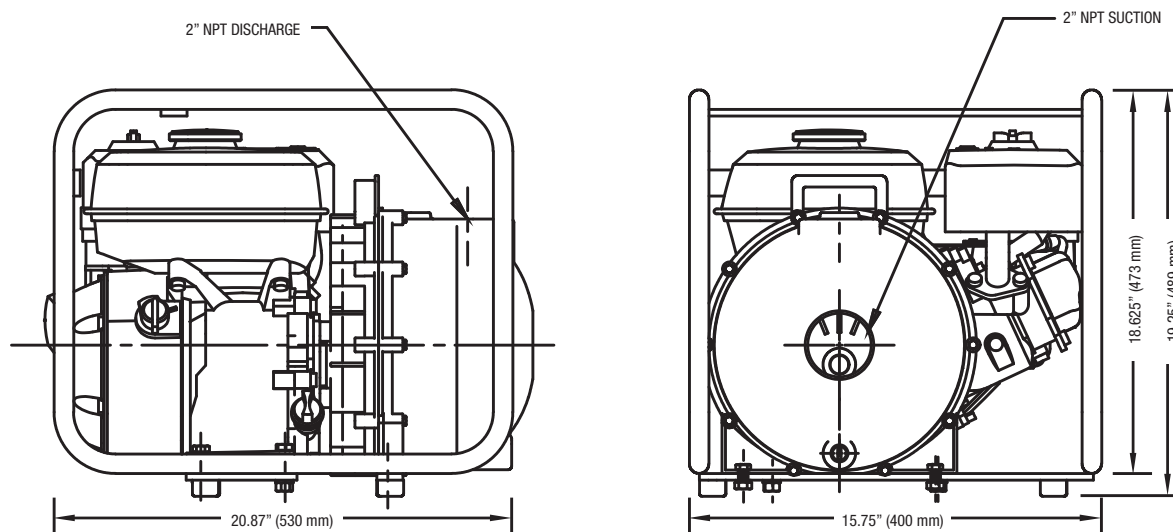

P-MAX Performance Curves

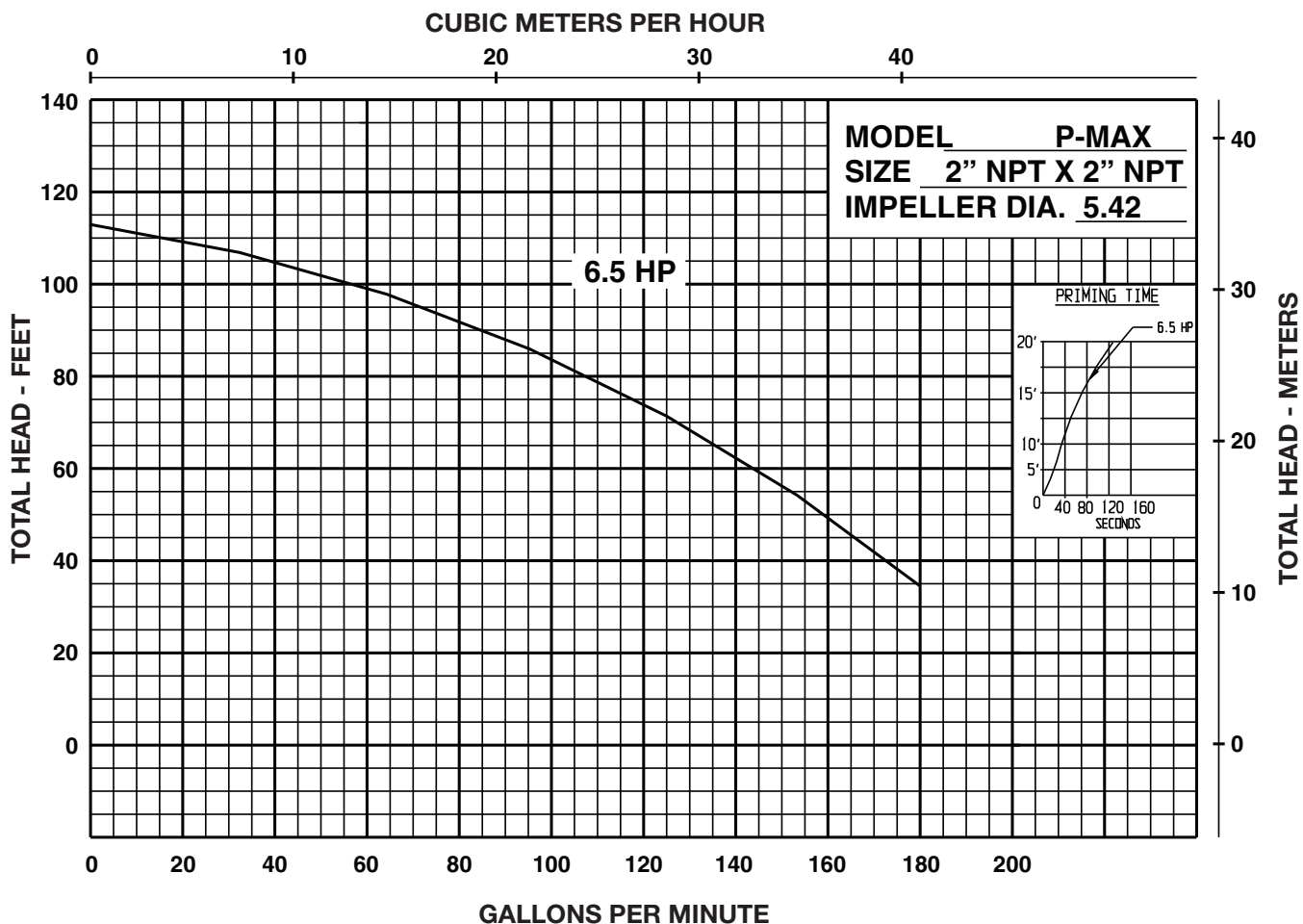

34800 BENNETT • FRASER, MI 48026-1686
 (586) 293-8240 • FAX (586) 293-8469
 (800) 563-8006 • www.mppumps.com