

NOTE: THIS DRAWING OR PRINT, PROPERTY OF MPPUMPS, INC. CONTAINS PROPRIETARY AND CONFIDENTIAL INFORMATION. IT SHALL BE USED ONLY AS APPROVED BY MPPUMPS AND SHALL NOT BE GIVEN TO OTHERS OR COPIED WITHOUT THE WRITTEN CONSENT OF MPPUMPS. RETURN TO MPPUMPS PROMPTLY WHEN REQUESTED.

G						UNLESS OTHERWISE NOTED THIRD ANGLE PROJECTION 2 PLACE DIM \pm .020 3 PLACE DIM \pm .010 ANGULAR DIM \pm 1°	MP PUMPS, INC. FRASER, MICHIGAN 48026, U.S.A.					
F					MATERIAL					MATERIAL SPECS		
E							DRAWN BY	DATE COMP.	APPROV.	SCALE	MADE FOR	MADE FROM
D							SF	6/9/20	BB			
C							DO NOT SCALE					
B						NAME					DRAWING NO	
A	UPDATED DWG	ECN 1134216	SF	6/9/20	BB	FM8PMP C:PED/HYD HS .37 DISP FA 5.0					MP36592	
REV	DESCRIPTION		DRAWN	DATE	EN							

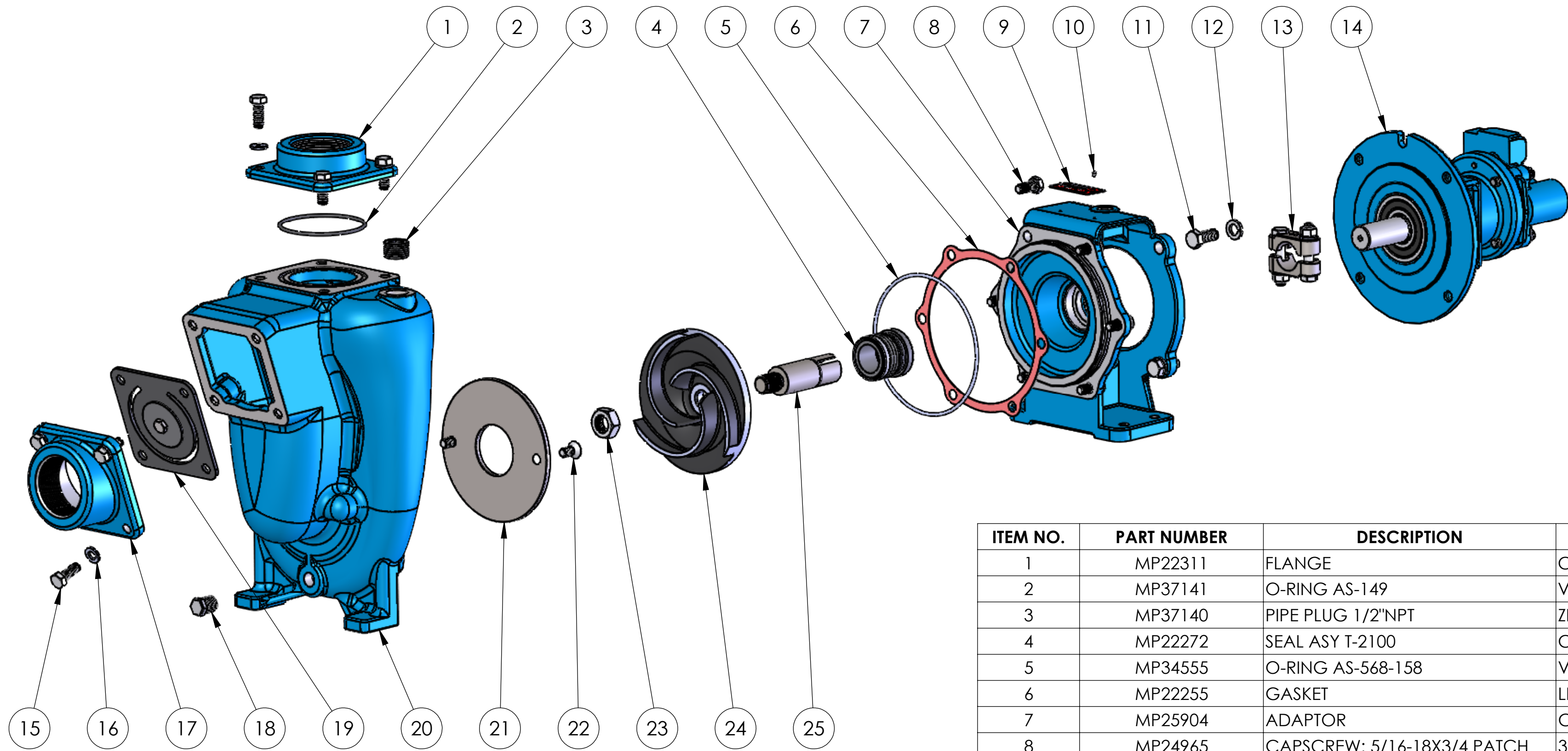

ITEM NO.	PART NUMBER	DESCRIPTION	MATERIAL	QTY.
1	MP22311	FLANGE	CAST IRON	1
2	MP37141	O-RING AS-149	VITON	1
3	MP37140	PIPE PLUG 1/2"NPT	ZINC PLATED STEEL	1
4	MP22272	SEAL ASY T-2100	CCS VITON	1
5	MP34555	O-RING AS-568-158	VITON	1
6	MP22255	GASKET	LEXIDE NI-2085	1
7	MP25904	ADAPTOR	CAST IRON	1
8	MP24965	CAPSCREW: 5/16-18X3/4 PATCH	304 SS	6
9	MP21183	NAME PLATE	ALUMINUM	1
10	MP21122	DRIVE SCREW	304 SS	2
11	MP21251	CAPSCREW: 3/8-16X7/8	304 SS	4
12	MP21266	LOCKWASHER 3/8 X 1/8	304 SS	4
13	MP23003	CLAMP ASSEMBLY	303 SS	1
14	MP35998	HS HYDRAULIC PEDESTAL .45	CAST IRON	1
15	MP21242	CAP SCREW HH 5/16-18 X 7/8	304 SS	8
16	MP21238	LOCKWASHER 5/16 X 18	304 SS	10
17	MP22387	SUCTION FLANGE	CAST IRON	1
18	MP41475	PIPE PLUG:1/4 NPT	STEEL	1
19	MP23022	FLAPPER ASSEMBLY	BUNA	1
20	MP22251	HOUSING	CAST IRON	1
21	MP22260	WEAR PLATE	STEEL	1
22	MP37137	SCREW FHS 5/16-18 X 5/8	304 SS	2
23	MP22655	HEX JAM NUT	304 SS	1
24	MP22293	IMPELLER	CAST IRON	1
25	MP25664	DRIVE SLEEVE	303 SS	1

NOTE: THIS DRAWING OR PRINT, PROPERTY OF MPPUMPS, INC., CONTAINS PROPRIETARY AND CONFIDENTIAL INFORMATION. IT SHALL BE USED ONLY AS APPROVED BY MPPUMPS AND SHALL NOT BE GIVEN TO OTHERS OR COPIED WITHOUT THE WRITTEN CONSENT OF MPPUMPS. RETURN TO MPPUMPS PROMPTLY WHEN REQUESTED.

G						UNLESS OTHERWISE NOTED THIRD ANGLE PROJECTION 2 PLACE DIM ± .020 3 PLACE DIM ± .010 ANGULAR DIM ± 1°	MP PUMPS, INC. FRASER, MICHIGAN 48026, U.S.A.					
F					MATERIAL						MATERIAL SPECS	
E							DRAWN BY	DATE COMP.	APPROV.	SCALE	MADE FROM	MADE FROM
D							SF	6/9/20	BB			
C							DO NOT SCALE					
B						NAME					DRAWING NO	
A	UPDATED DWG	ECN 1134216	SF	6/9/20	BB	FM8PMP C:PED/HYD HS .37 DISP FA 5.0					MP36592	
REV	DESCRIPTION		DRAWN	DATE	EN							