

### MODEL 3872 - WW05 Series

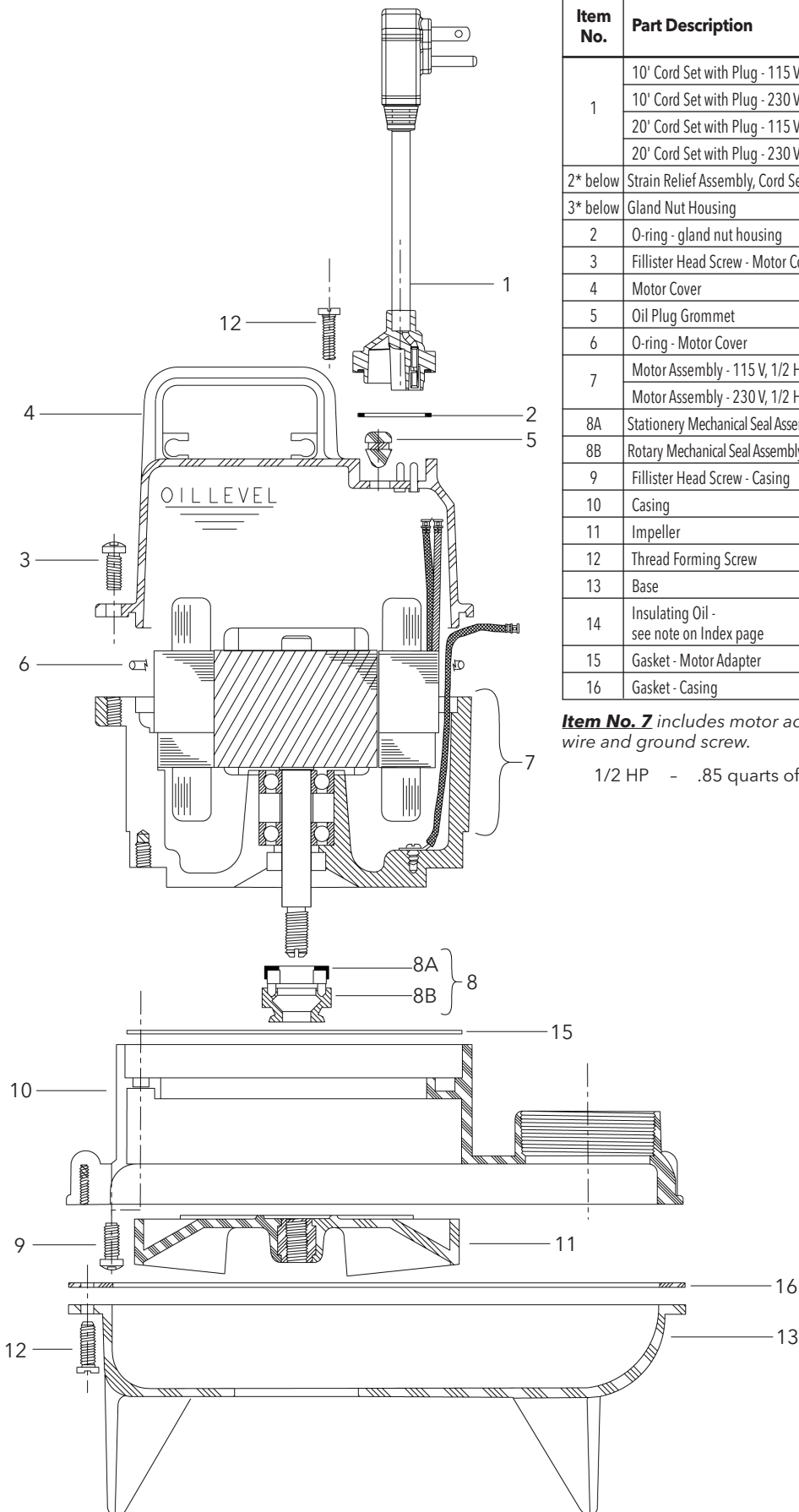

Item No.	Part Description	Material	Qty. Req.	Before 2/1/12 Part No.	After 2/1/12 Part No.
1	10' Cord Set with Plug - 115 V	SJTOW - 16/3	1	9K207	9K531
	10' Cord Set with Plug - 230 V			9K208	9K532
	20' Cord Set with Plug - 115 V			9K533	9K533
	20' Cord Set with Plug - 230 V			9K210	9K534
2* below	Strain Relief Assembly, Cord Set	Varies	1	5K113	not needed
3* below	Gland Nut Housing	Thermoplastic	1	9K226	not needed
2	O-ring - gland nut housing	Buna-N, AS 568A-024	1	5K197	5K197
3	Fillister Head Screw - Motor Cover	AISI 300 SS	4	13K347	13K347
4	Motor Cover	Thermoplastic	1	1K257	1K257
5	Oil Plug Grommet	Buna-N	1	6K87	6K87
6	O-ring - Motor Cover	Buna-N, AS 568A-161	1	5K196	5K196
7	Motor Assembly - 115 V, 1/2 HP	Varies	1	1K284	1K284
	Motor Assembly - 230 V, 1/2 HP			1K285	1K285
8A	Stationery Mechanical Seal Assembly	Carbon/Ceramic	1	10K32	10K32
8B	Rotary Mechanical Seal Assembly				
9	Fillister Head Screw - Casing	AISI 300 SS	4	13K347	13K347
10	Casing	Thermoplastic	1	1K274	1K274
11	Impeller	Thermoplastic	1	2K494	2K494
12	Thread Forming Screw	AISI 300 SS	10	13K243	13K243
13	Base	Thermoplastic	1	1K275	1K275
14	Insulating Oil - see note on Index page	Turbine Oil - ATSM 150	-	4K432	4K432
15	Gasket - Motor Adapter	Composite	1	5K182	5K182
16	Gasket - Casing	Composite	1	5K217	5K217

**Item No. 7** includes motor adapter, rotor, stator, tolerance ring, ground wire and ground screw.

1/2 HP - .85 quarts of insulating oil required.

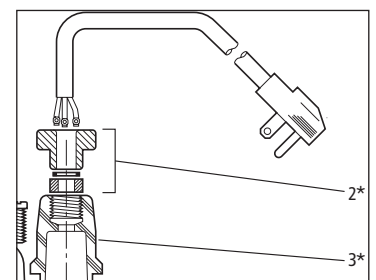

\* Not needed after 2/1/2012.

**NOTE:** Pump with cord sets previous to 2/1/2012 can not be repaired after 2/1/2012.

**NOTE:** After 5/11, new cord design eliminates gland as separate component.