

E1456



Portable Spot Free Rinse System

Spot Free Rinse Water, Whenever, Wherever Needed

Now a **Portable RO Spot Free Rinse Systems** that does not require storage tanks. Simply attach your water supply hose from Municipal water to the DTS+Mobile System and immediately rinse with spot free water. This unique portable system removes up to 99% of total dissolved solids, (TDS) which is what causes water spotting. Ideal as a final, low-pressure rinse for mobile pressure washing, vehicle detailers, soft wash cleaners, auto/truck dealers and more.

- Greatly reduce wash/rinse time due to no longer needing to towel dry
- Eliminates hard water buildup
- Reduce scratches or swirl marks from towels
- Direct use means no need for storage tanks
- In addition, using RO water in your chemical solution tank reduces chemical mix rates and usage.



Standard Features

- Portable design can be easily moved, transported and stored.
- Compact size, 51" long, 14-3/4" wide, 15-1/2" high.
- 100% sealed electrical plug receptacle.
- Intelligent control system with filter/membrane service indicator.
- Nema 4X/IP67 rated electrical enclosure.
- Twist handle flush valve.
- Dual handles and wheels for added portability.
- Easy access garden hose connections for inlet and outlet water (hoses not included).
- Operates from 15 to 100 PSI inlet water (outlet PSI is approximately the same as inlet).
- Typical output is 2.5 GPM at 50 PSI but higher flow rates at higher incoming PSI.
- 1/2 HP, 1 Phase, 120 Volt motor with GFIC protection. 11 AMP draw rating.
- Pre-filter life is approximately 100 hours.
- RO membrane life is approximately 25,000 gallons of RO water at 500 PPM water input.



Part No.	Valve Size	Wt.
FC DTS120	Mobile Spot Free Unit, 120 Volt	170 lbs.
FC 20-7111	Pre-filter as replacement	
FC 10-1623	Membrane as replacement	

* Free freight to continental US

- ERGONOMICALLY designed handles for easy lifting
- 100% Sealed electrical plug with watertight cap
- LARGE WHEELS for easy movement and mobility
- FILTER CHANGE INDICATOR lets you know when it's time to change your filter
- ON / OFF TOUCH CONTROL SWITCH for easy use and safety

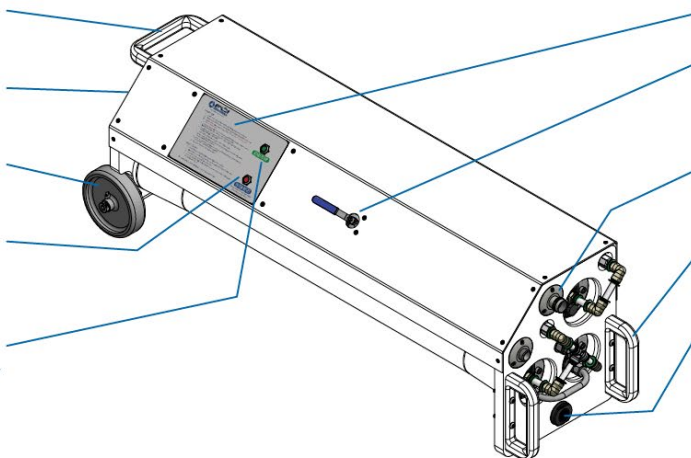

- NEMA 4X / IP 67 Rated Enclosure
- FLUSH / OPERATION VALVE uses a simple twist handle to select operation mode
- EASY-ACCESS HOSE CONNECTIONS for quick setup and take-down
- DUAL HANDLES for easy movement
- BRINE DISCHARGE automatically shuts off to save operational cost and water